

# Lecture #5

---

## SECTION VIEW

# This week

---

You will learn creating sectional views.

The steps to follow are:

- Cutting plane
- Kind of section views (full, half, etc.)
- Section line symbols
- Conventional practice
- Assembly sections
- Creating section views in AutoCAD
- **Assignment # 4**

# Principles

---

CREATING SECTIONS

# Sectional views are usually produced

---

To clarify details of the object

To illustrate internal features clearly

To reduce the number of hidden detail lines

To facilitate the dimensioning of internal features

To show the shape of the cross-section

To show clearly the relative positions of forming an assembly

# Sectional views

Newly visible edges cut by cutting plane are crosshatched with section lining.

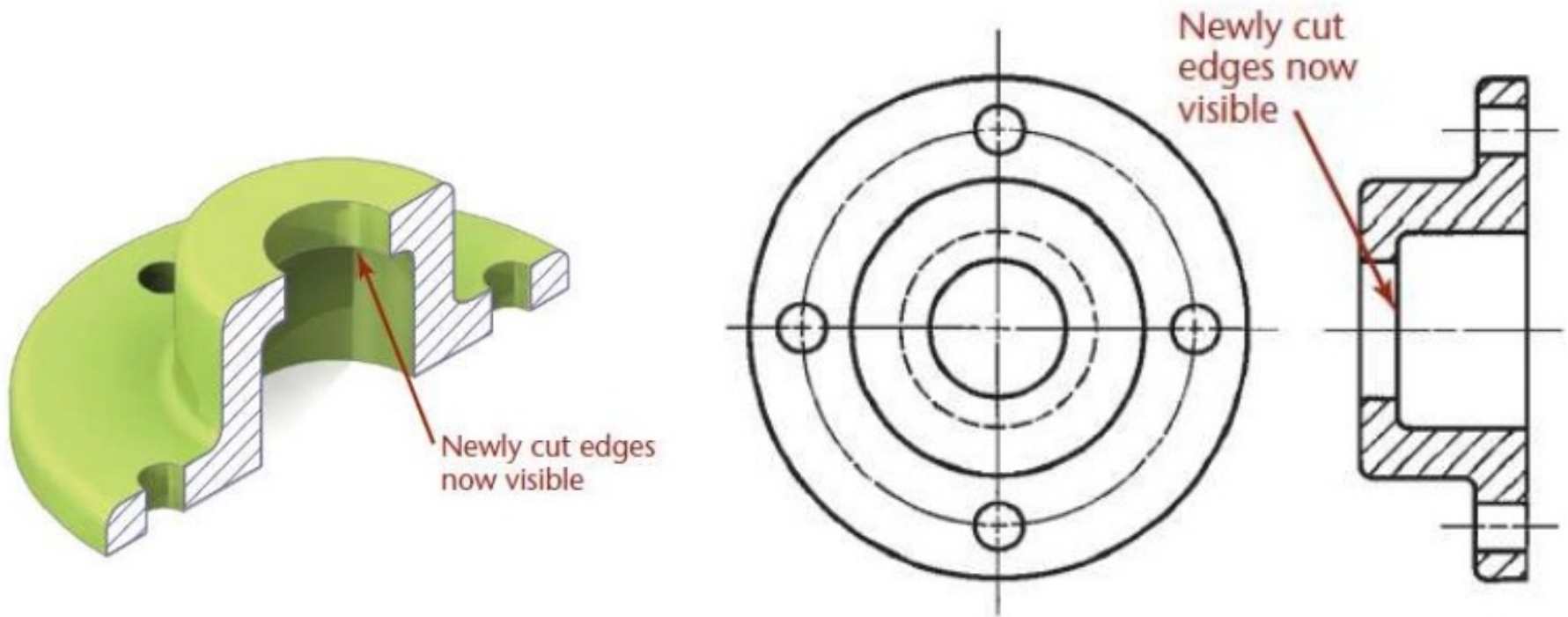

# Cutting plane

***Cutting plane*** is a plane that ***imaginarily cuts*** the object to reveal the internal features.

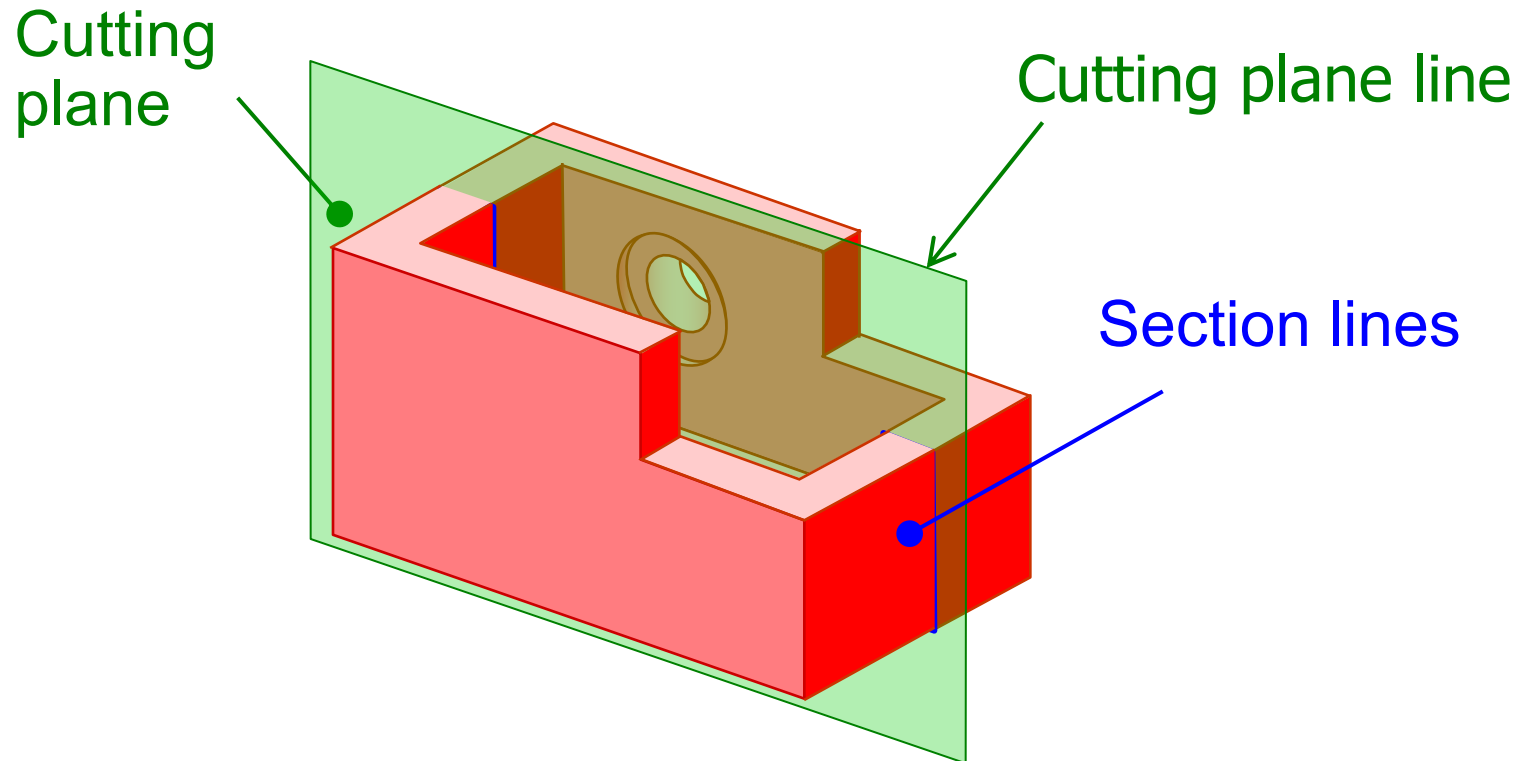

# Cutting plane line

*Cutting plane line* is an *edge view* of the cutting plane.

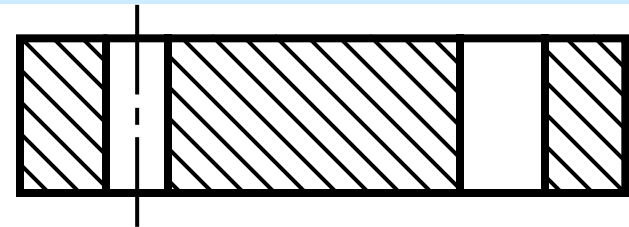
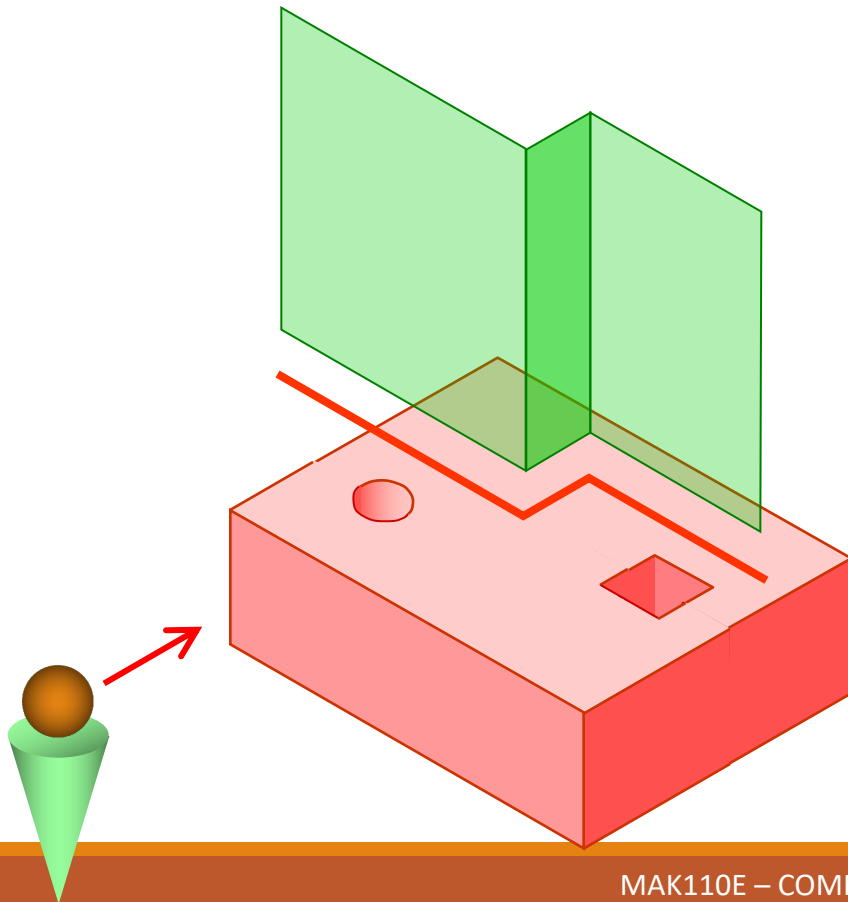

Indicate the *path* of cutting plane.

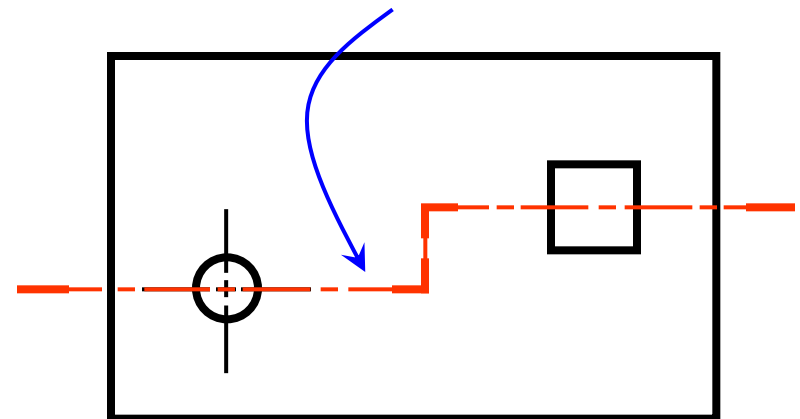

# Cutting plane line

---

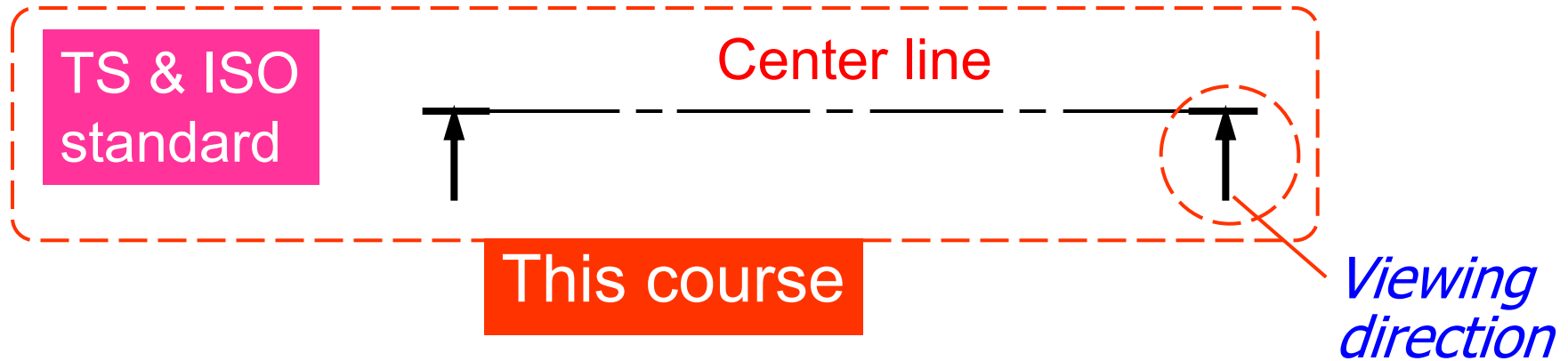

# Cutting plane line

ANSI  
standard

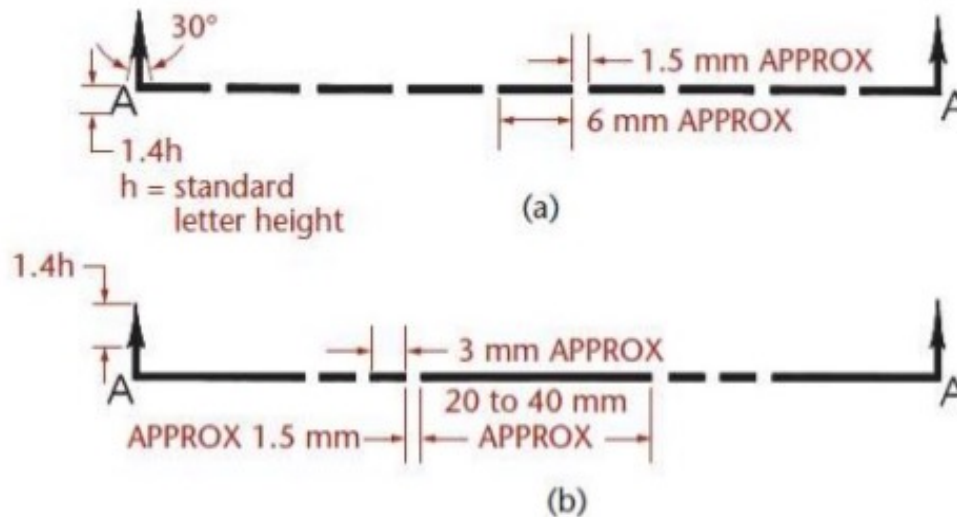
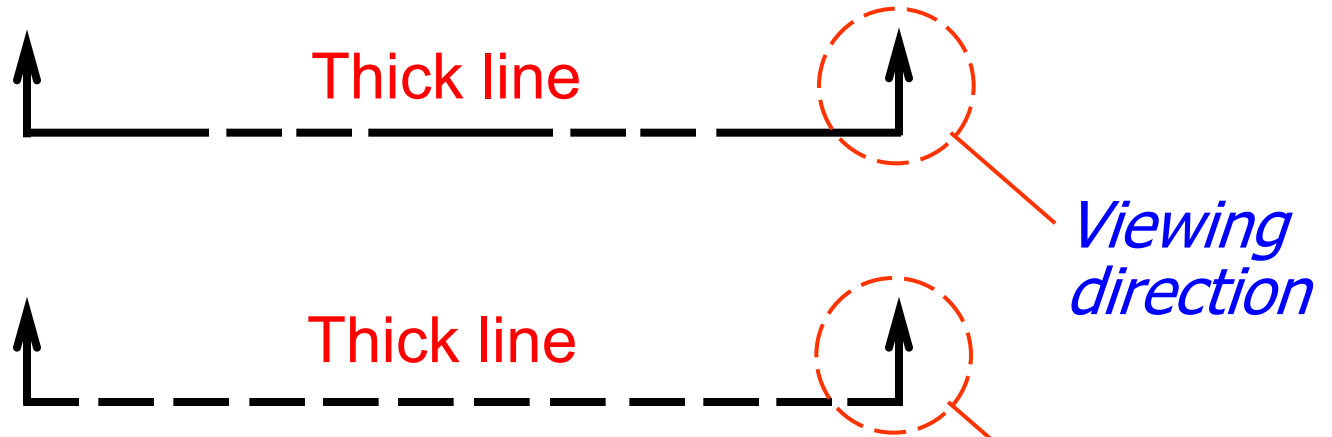

# Labeling cutting plane

Note that each section (A-A and B-B) is completely independent.

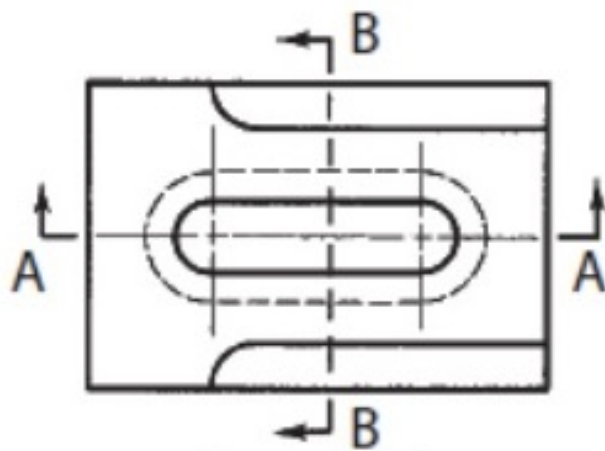

Section A-A

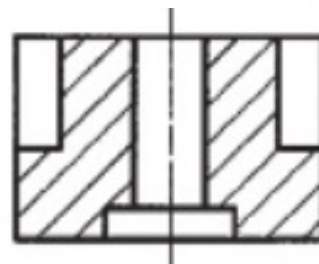
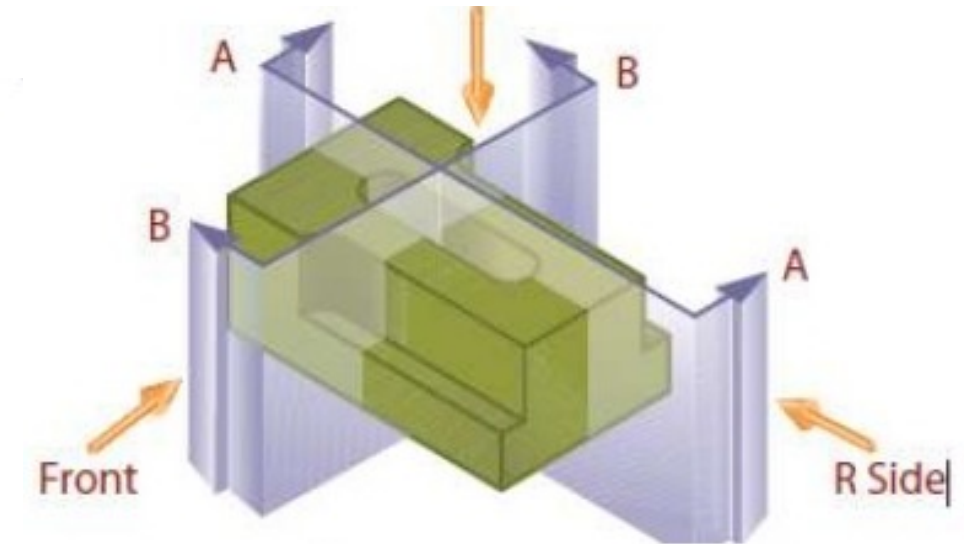

Section B-B

# Visualizing cutting plane

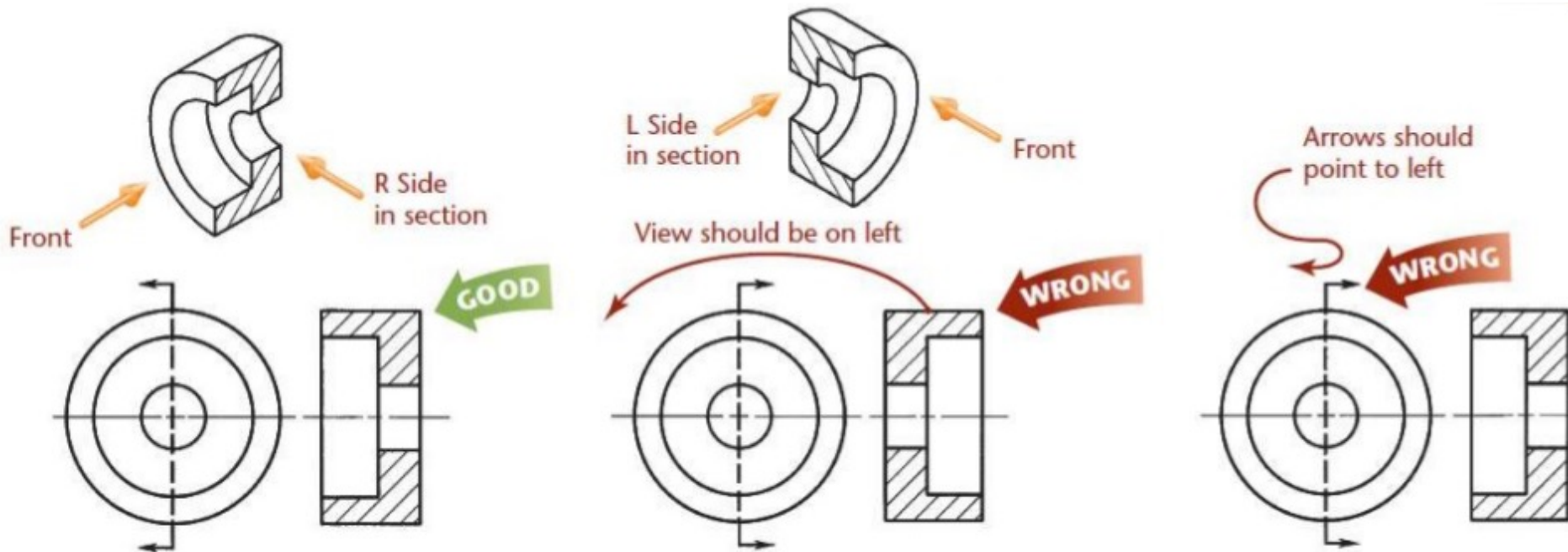

# Principles

---

KIND OF SECTIONS

# Kind of sections

---

1. Full section
2. Offset section
3. Half section
4. Broken-out section
5. Revolved section (aligned section)
6. Removed section (detailed section)
7. Aligned section

# Kind of sections

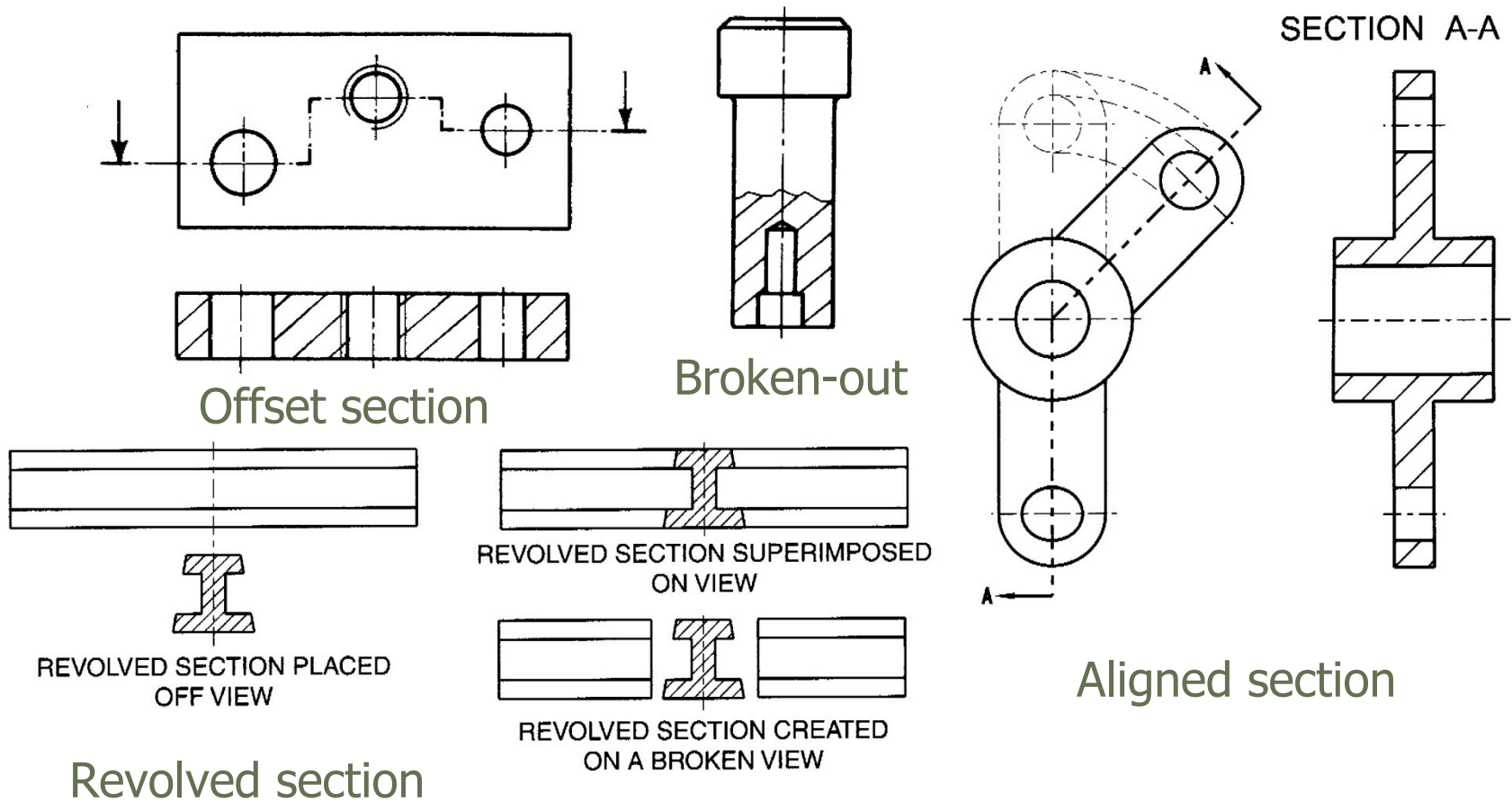

# Offset section view

The view is made by passing the **bended** cutting plane **completely through** the part.

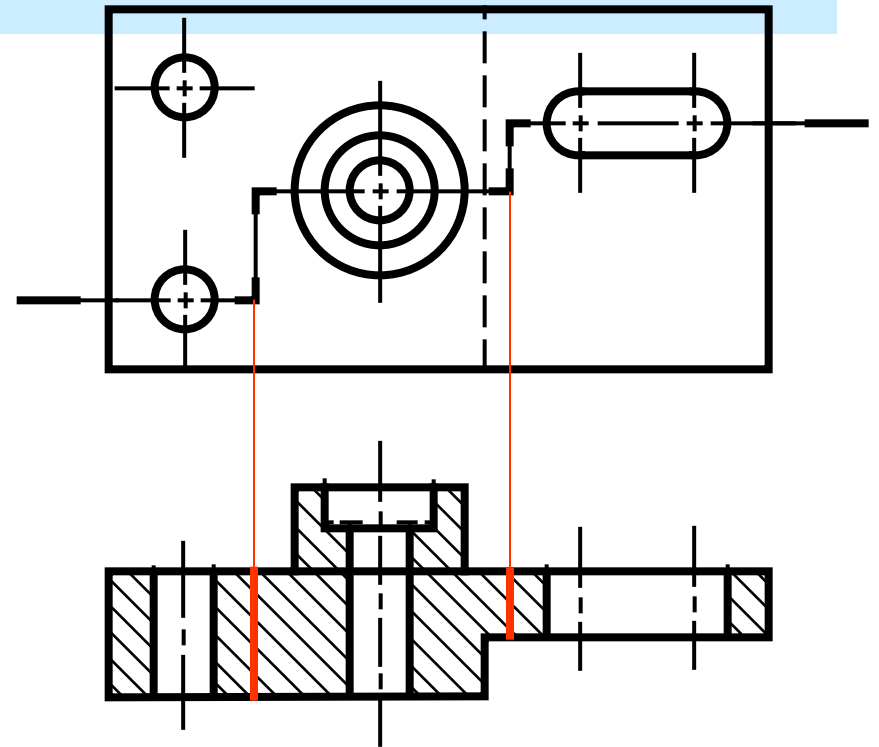
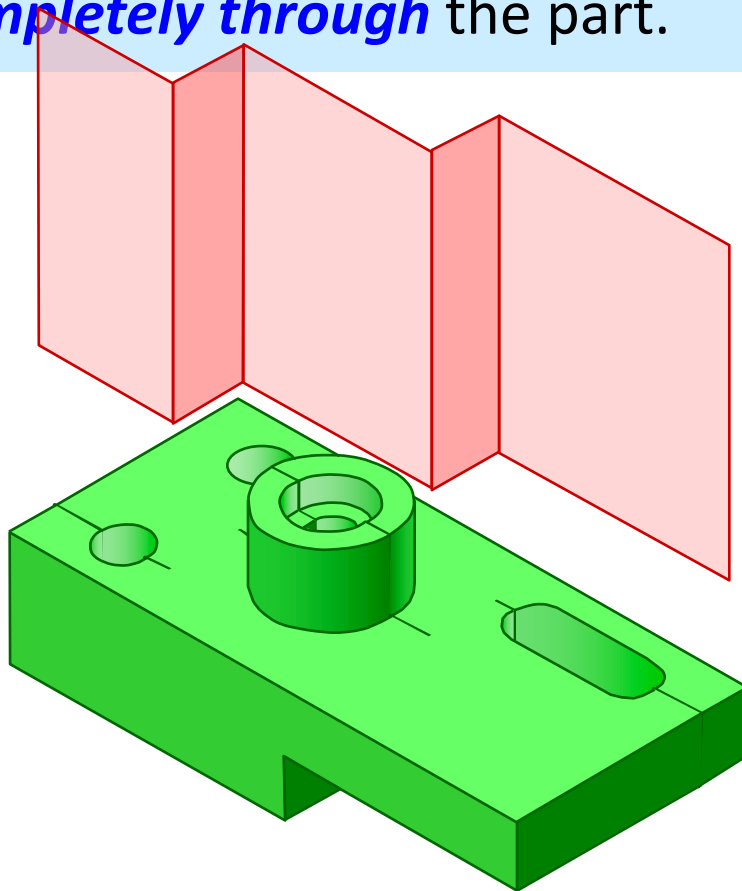

**Do not show the edge views of the cutting plane.**

# Broken-out section view

The view is made by passing the cutting plane normal to the viewing direction and removing the portion of an object in front of it.

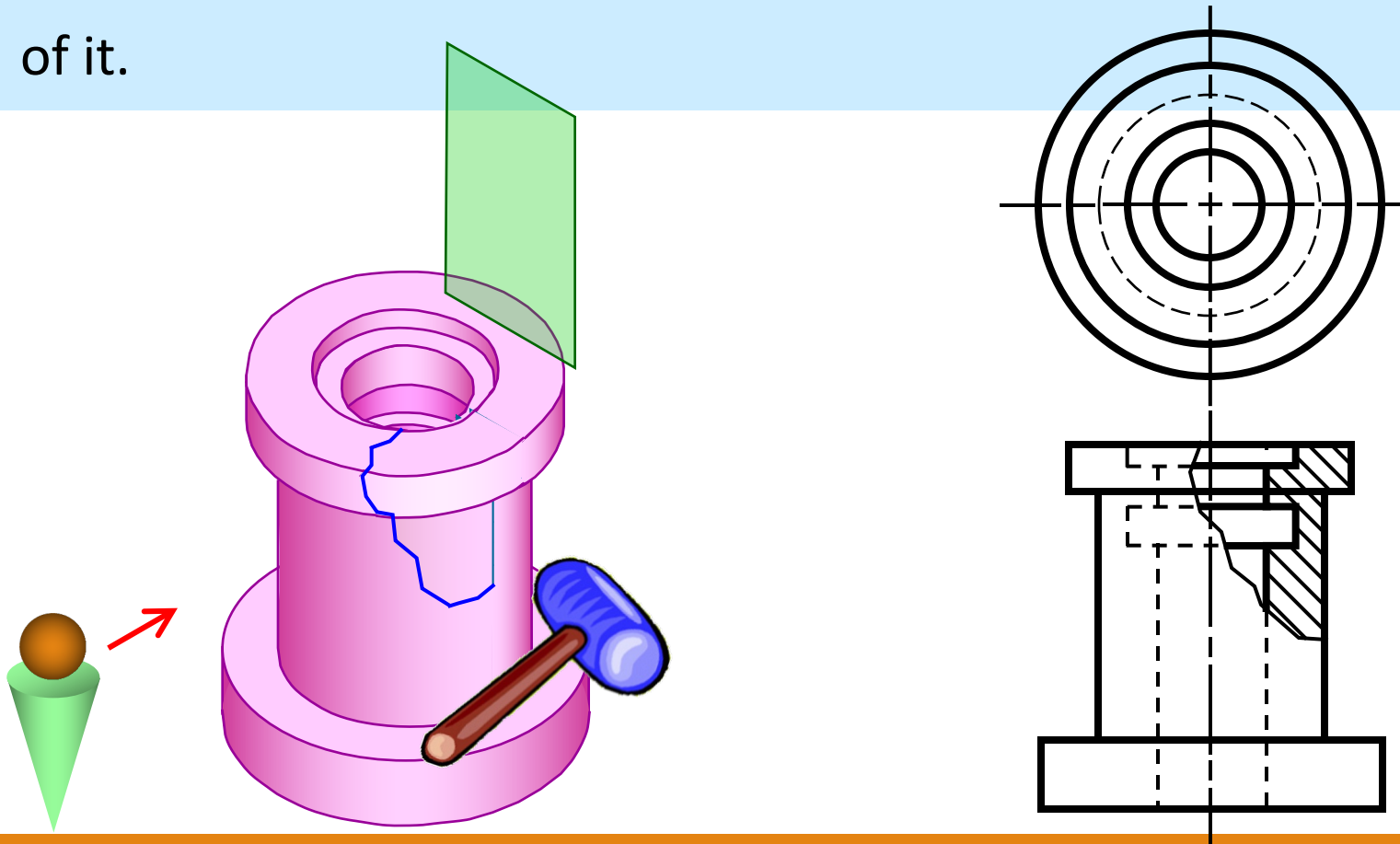

# Broken-out section view

- A **break line** is used to separate the sectioned portion from the unsectioned portion of the view.
- Break line is a thin continuous line (**0.25**) and is drawn freehand.
- There is **no** cutting plane line.

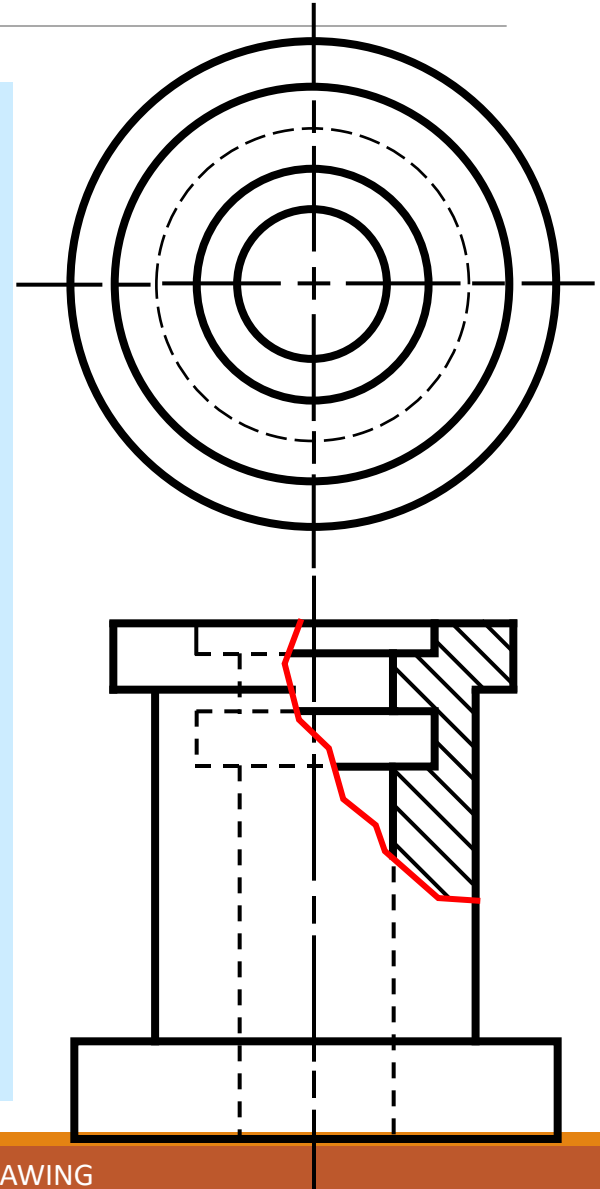

# Sketch

not in any menu

```
Unknown command "CLEAR". Press F1 for help.  
Command: sketch  
Type = Line Increment = 1.0000 Tolerance = 0.5000  
Specify sketch or [Type/Increment/tolerance]: 0.001  
Specify sketch: |
```

136.7998, 17.8124, 0.0000



1. Type command
2. Type increment
3. Use mouse & sketch geometry

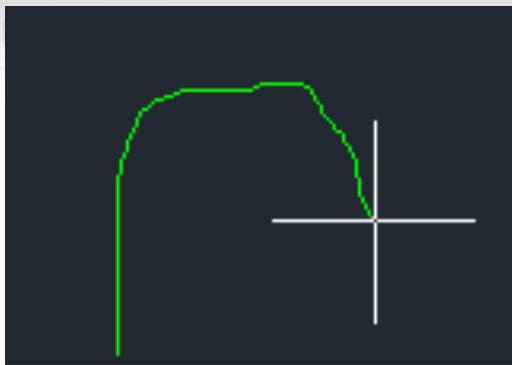

# Principles

---

## SECTION LINING

# Section line symbols

- Uniformly spaced by an interval of about 2.5 mm
- Not too close together
- Uniformly thin, not varying in thickness
- Distinctly thinner than visible lines
- Neither running beyond or not stopping short of visible outline

NO!

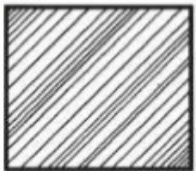

Spacing irregular

NO!

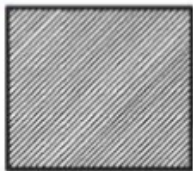

Lines too close

NO!

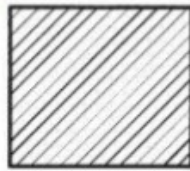

Varying line widths

NO!

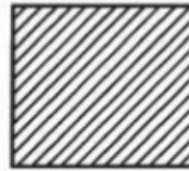

Lines too thick

NO!

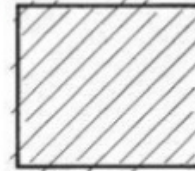

Lines short or overrunning

CORRECT

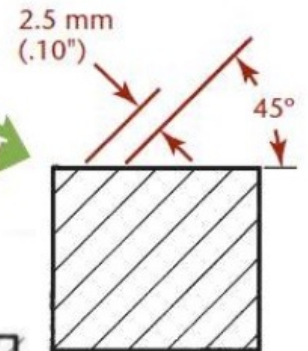

# Section line symbols

---

- The section lines are different for each of material's type.
- For practical purpose, the cast iron symbol is used most often for any materials.



Cast iron,  
Malleable iron



Steel



Concrete

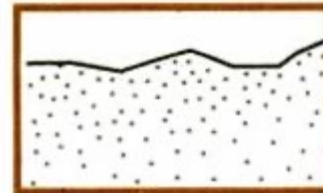

Sand



Wood

# Section line symbols

---

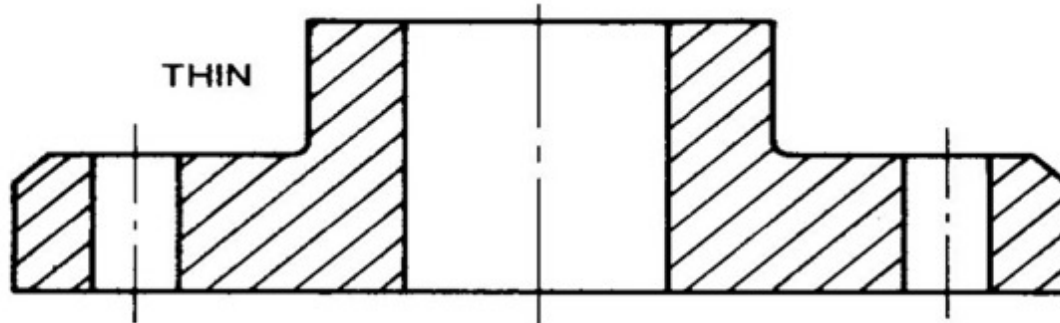

*Section lines.*

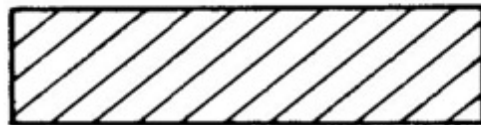

CAST IRON



STEEL



BRASS, BRONZE,  
COPPER, etc.



WHITE METAL, ZINC,  
LEAD, BABBITT



MAGNESIUM, ALUMINUM



PLASTIC, RUBBER, etc.

# Rules of lines in section view

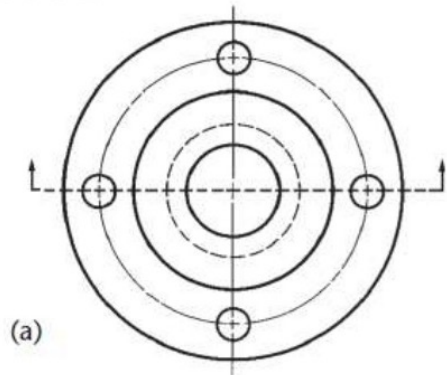

(a)

**GOOD**

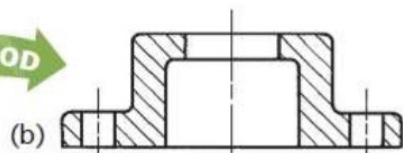

(b)

**POOR**

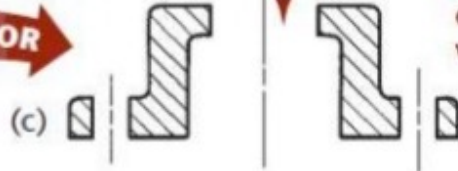

(c)

Show visible lines behind cutting plane when possible

**POOR**

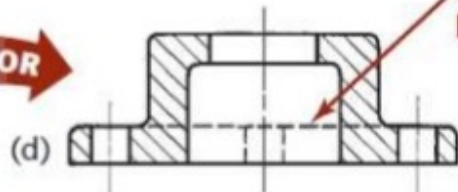

(d)

Omit hidden lines

**WRONG**

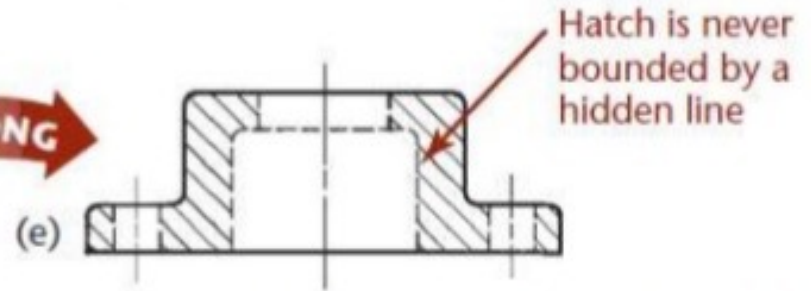

(e)

Hatch is never bounded by a hidden line

**WRONG**

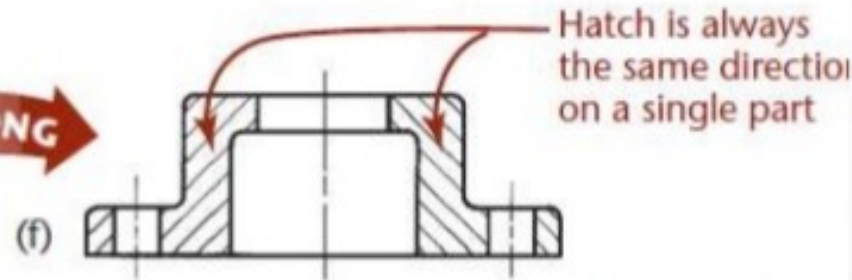

(f)

Hatch is always the same direction on a single part

**WRONG**

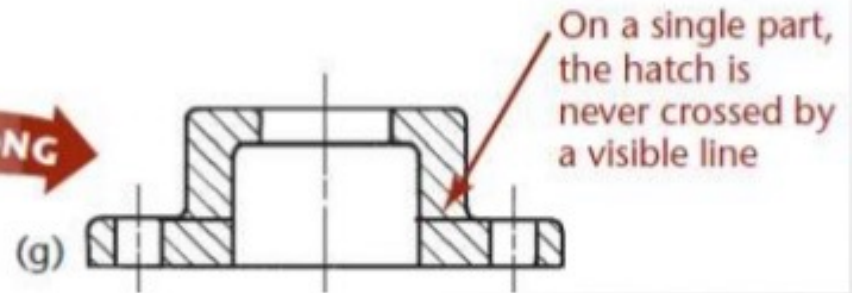

(g)

On a single part, the hatch is never crossed by a visible line

# Principles

---

CONVENTIONAL PRACTICE

# Conventional Practice

---

There are some exceptions to the general rules of sectioning:

- ❖ Webs, ribs, lugs, spokes,
- ❖ Shafts, rods, spindles,
- ❖ Bolts, nuts and thin washers.
- ❖ Rivets, dowels, pins and cotters.

# Terminology

---

**Rib** and **Web** are **thin, flat** feature of an object that acts as a structural support.



# Terminology

---

A ***web*** or ***rib*** is a strengthening or supporting part of a component.

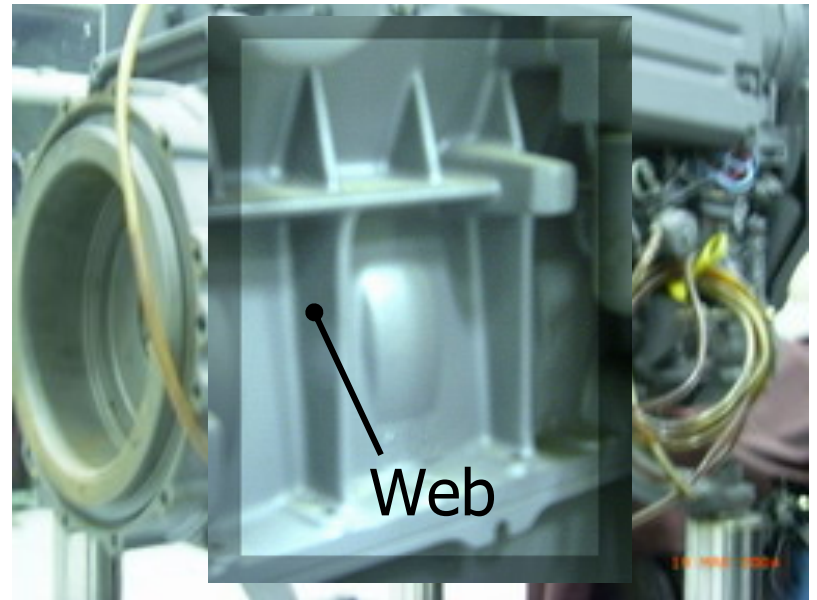

# Terminology

**Spoke** is the rod radiating from the **hub** to the **rim** of a wheel.

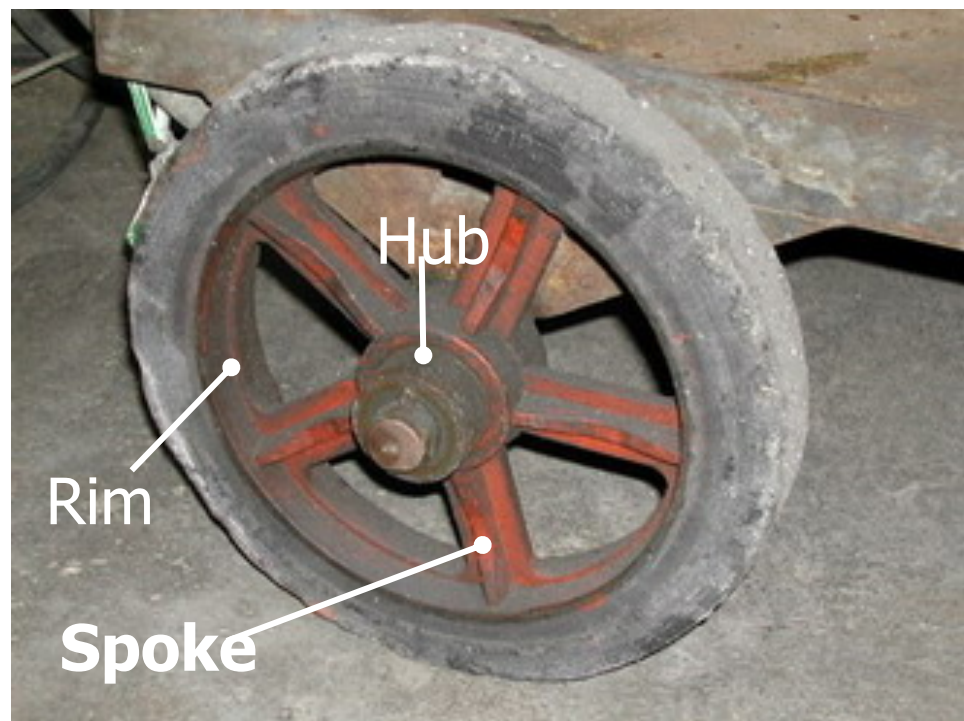
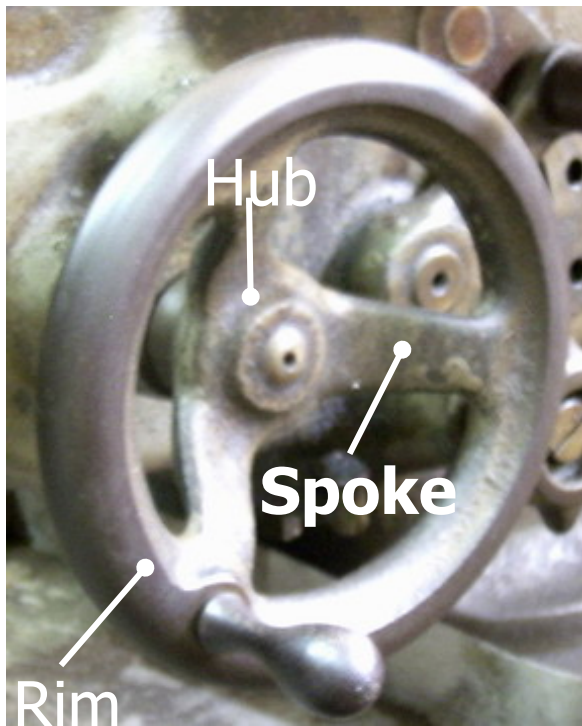

# Terminology

---

**Lug** is an ear which is built as portion of an object for attachment.



# Rib in sections

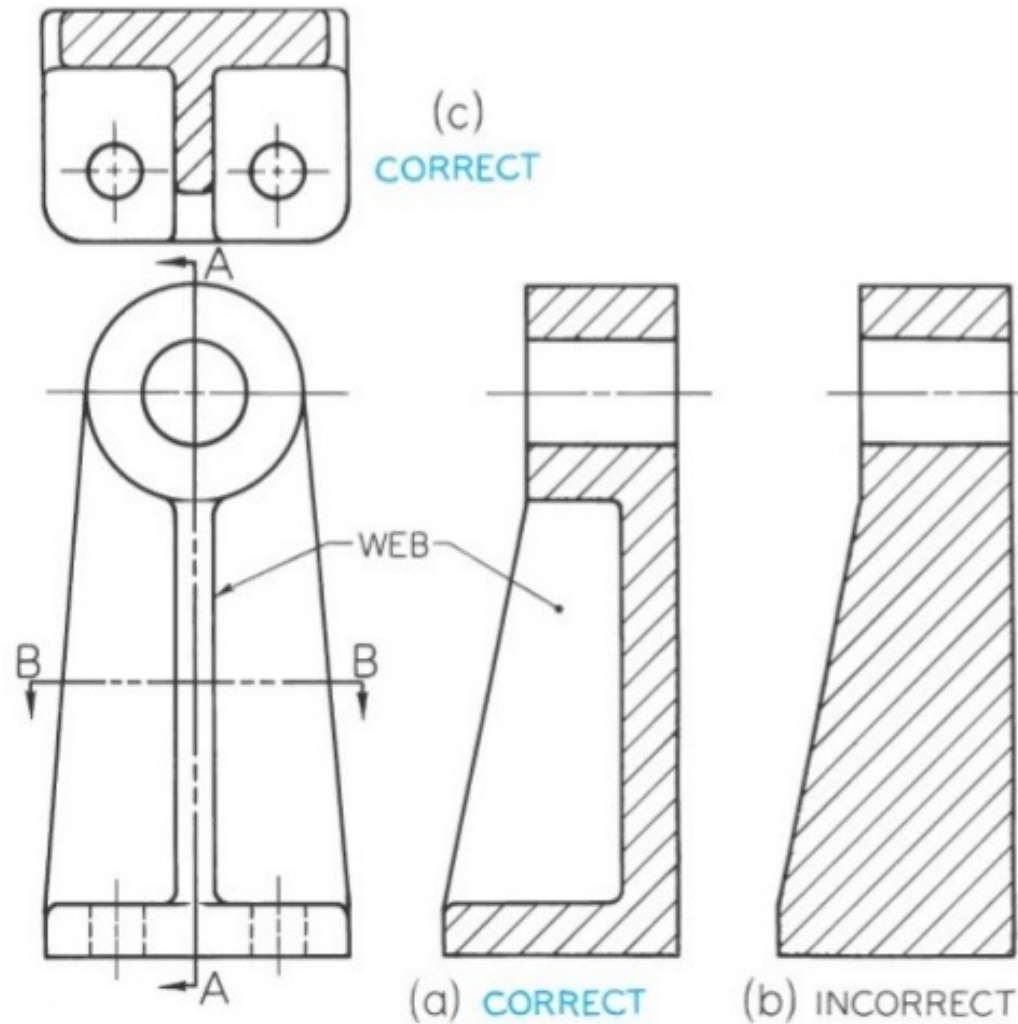

# Lug in sections

---

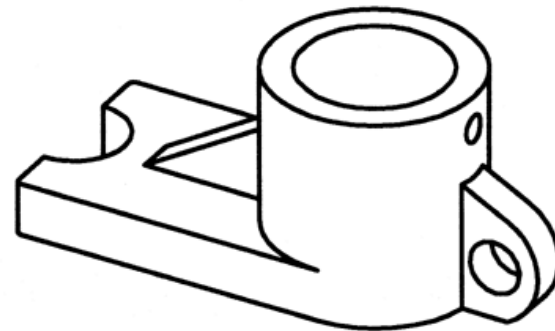
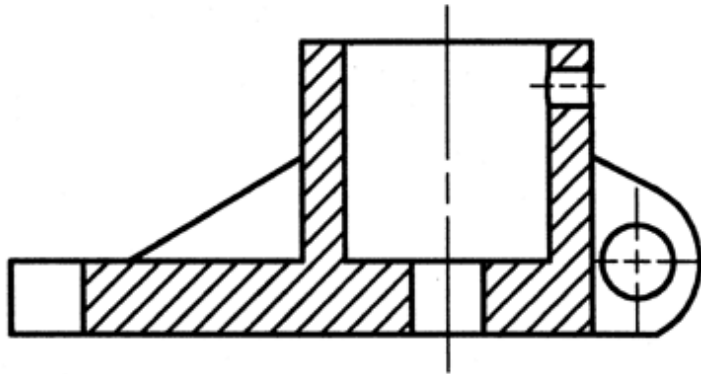
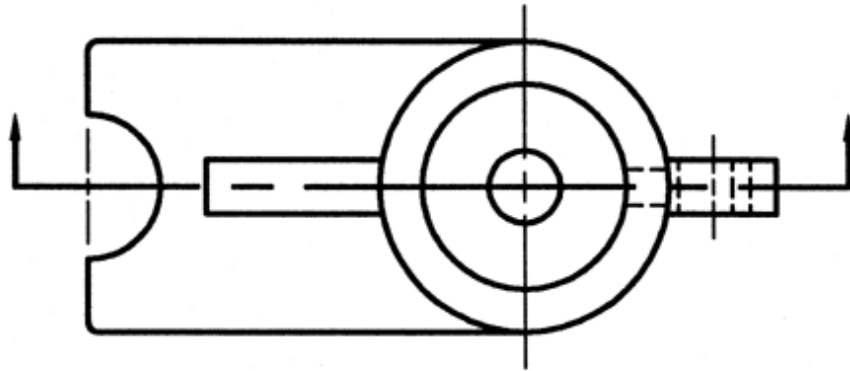

# Treatment of web & spoke

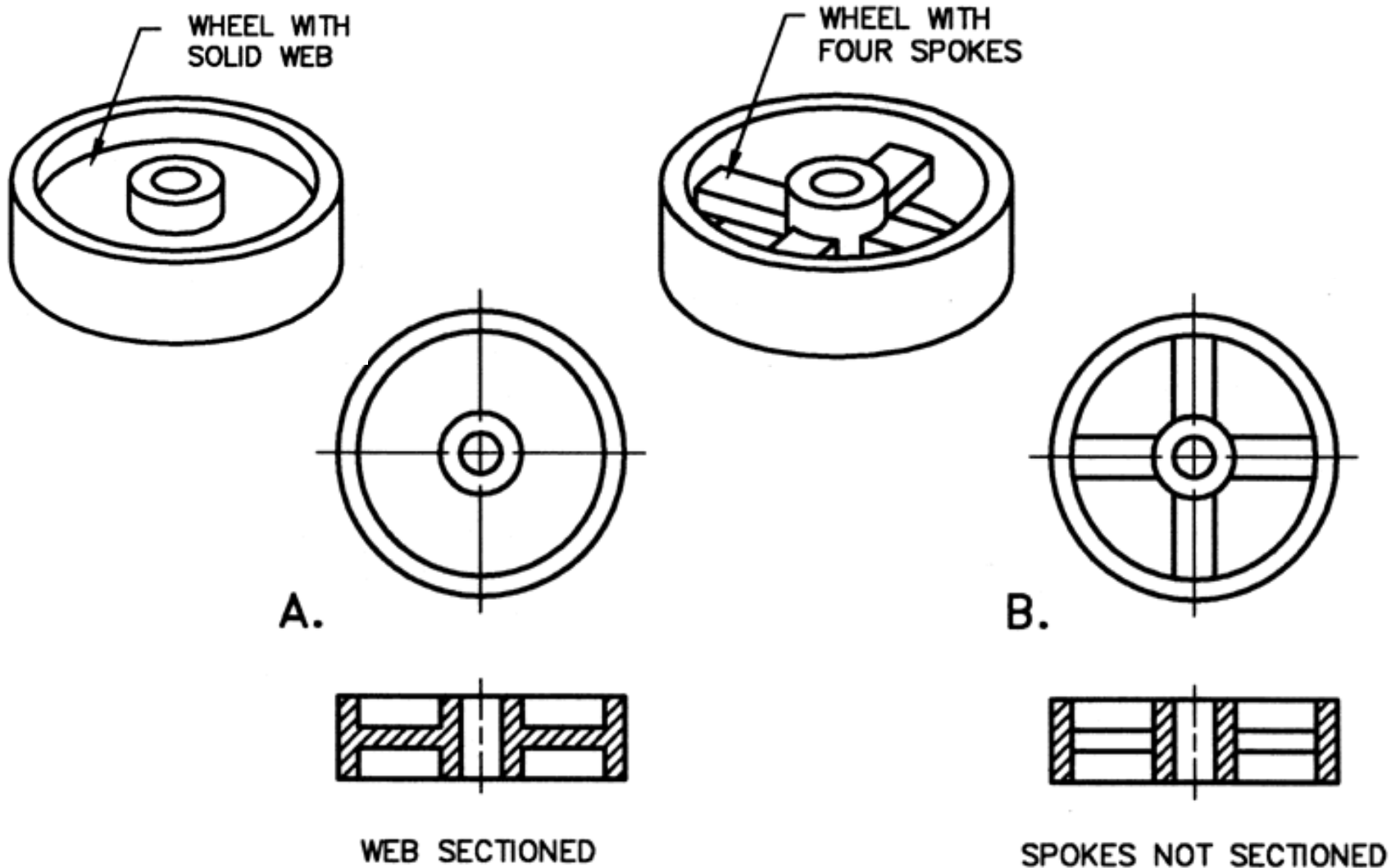

# Assembly section

- Views show how the parts fit together
- Individual components are identified by the use of numbers
- Adjacent components are hatched with a different properties (angle or scale)
- Standard components such as bolts, nuts are not hatched

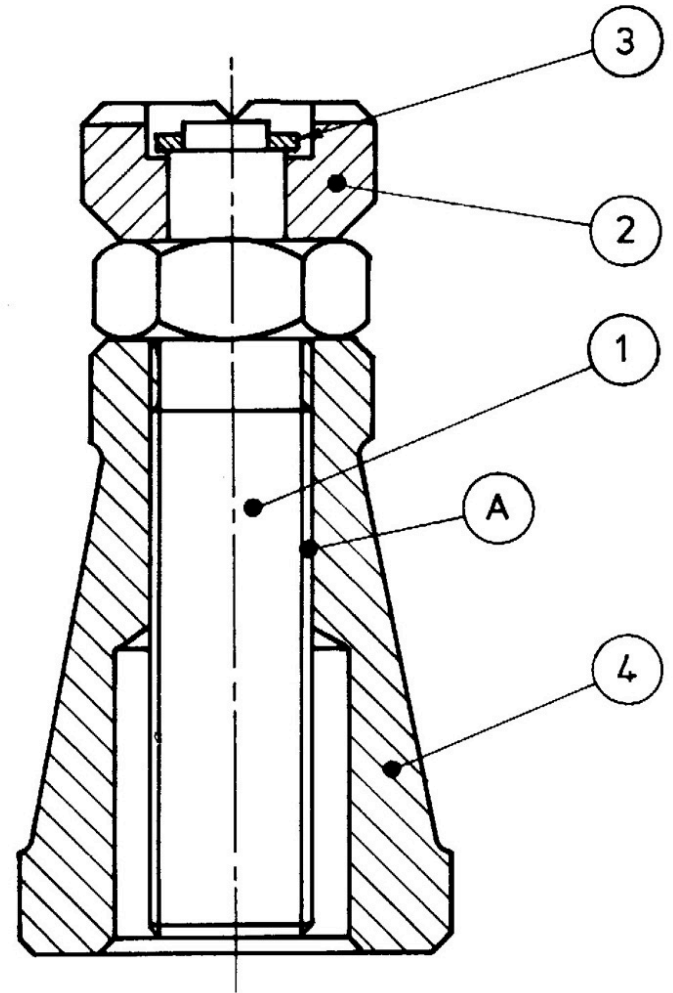

# Assembly section

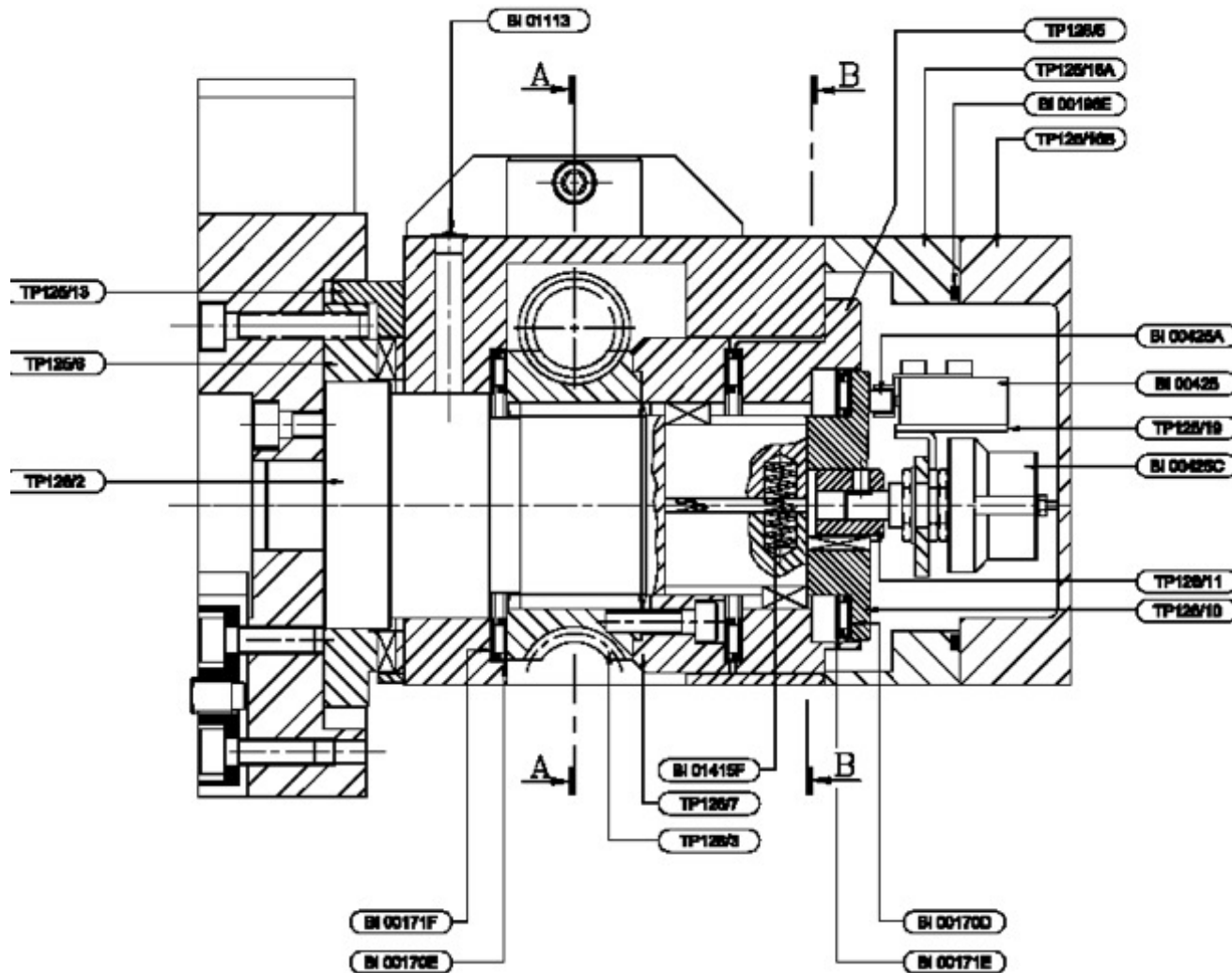

# Principles

---

CREATING SECTION VIEW IN AUTOCAD

# HATCH command

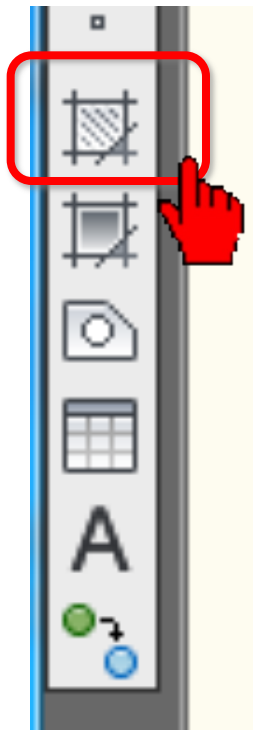

From icon menu

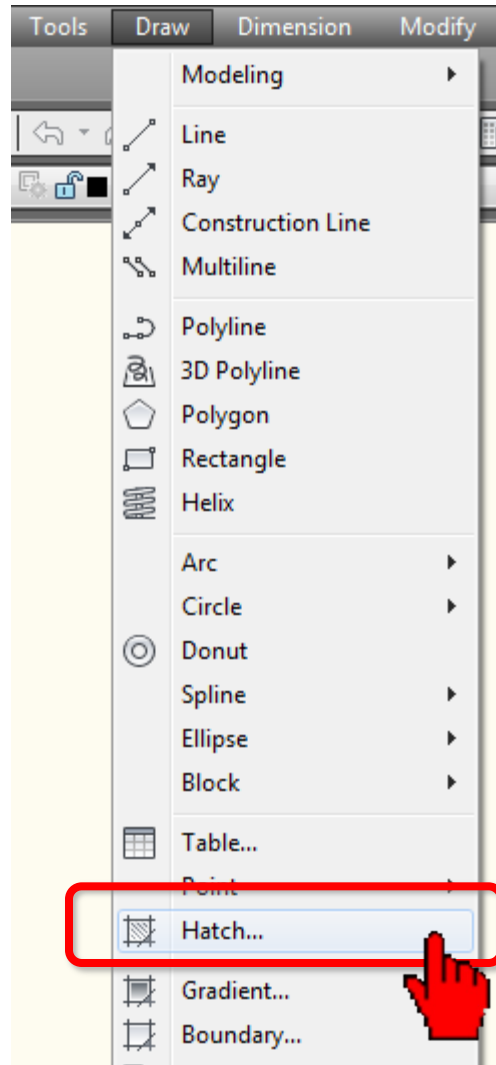

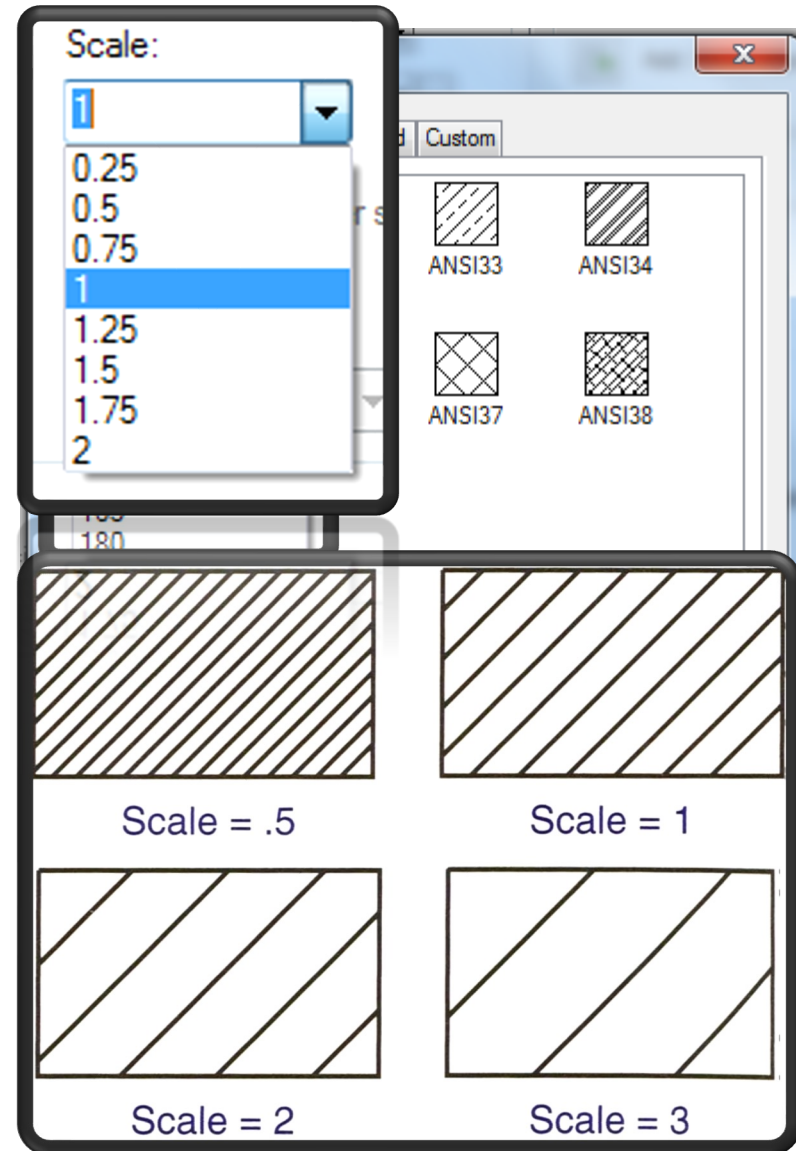
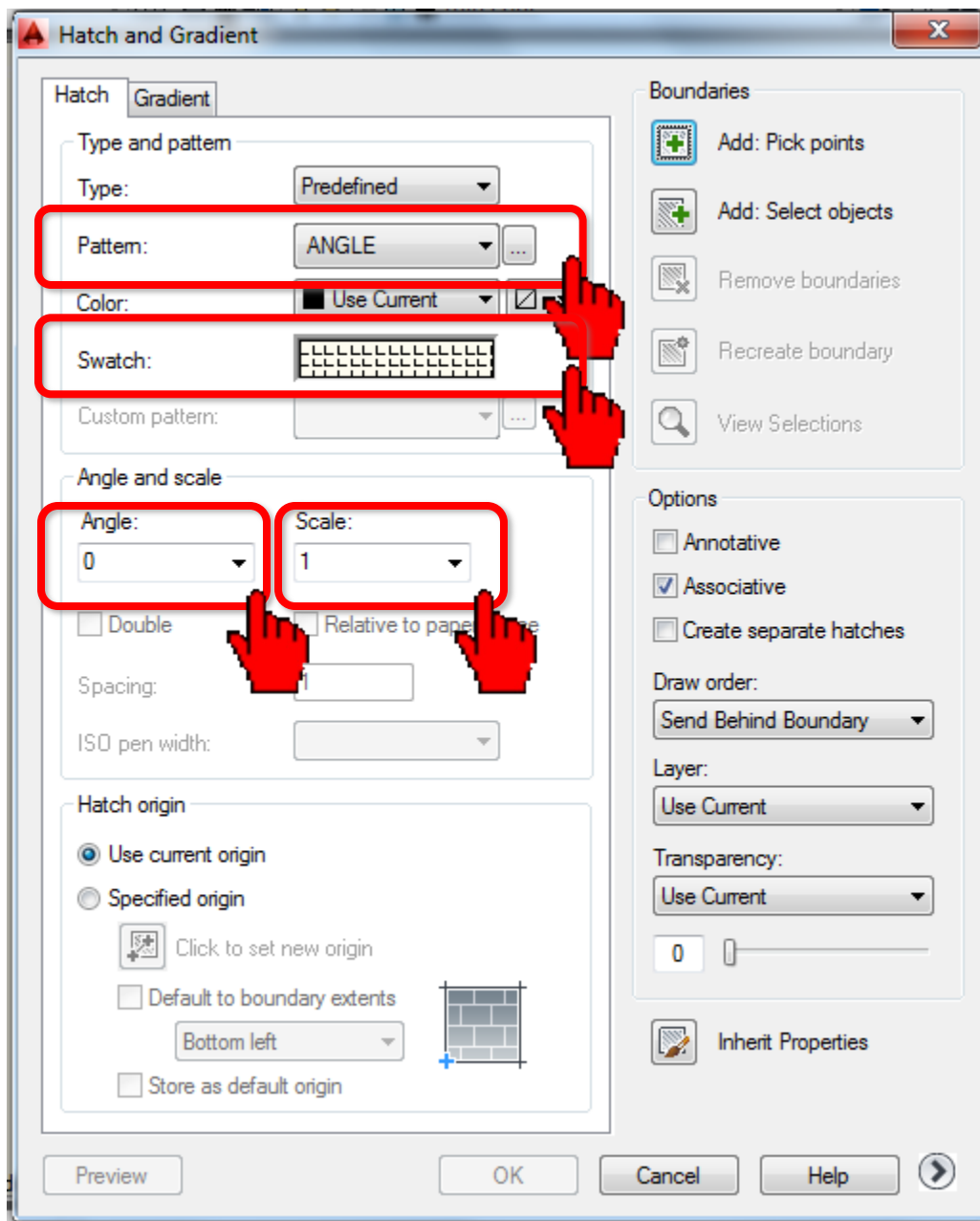

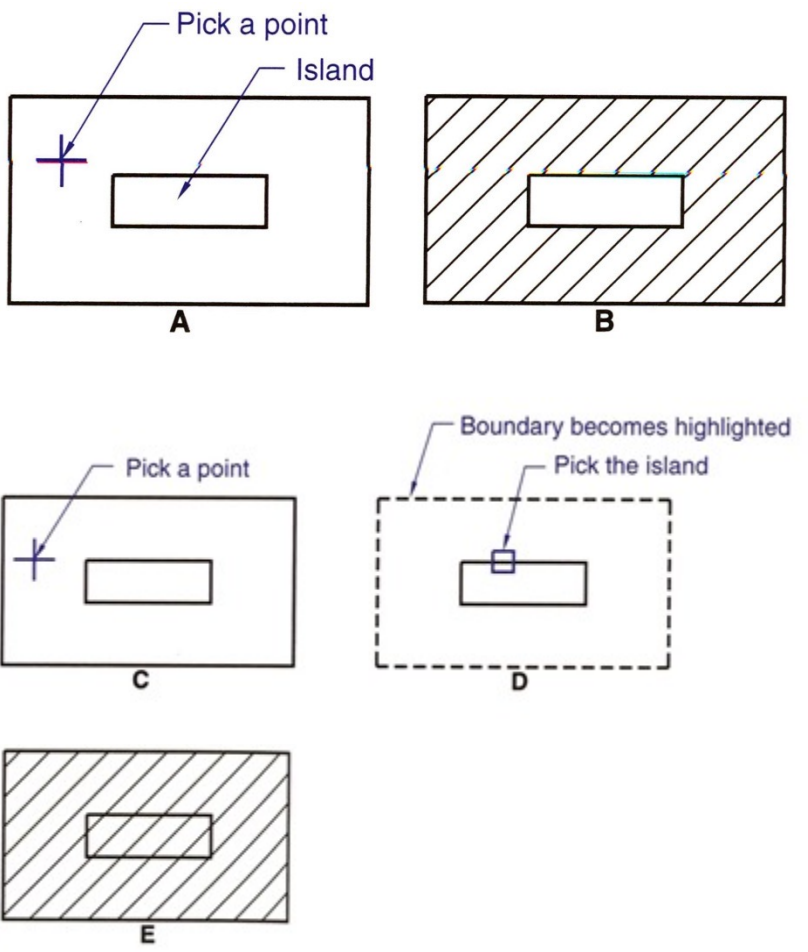
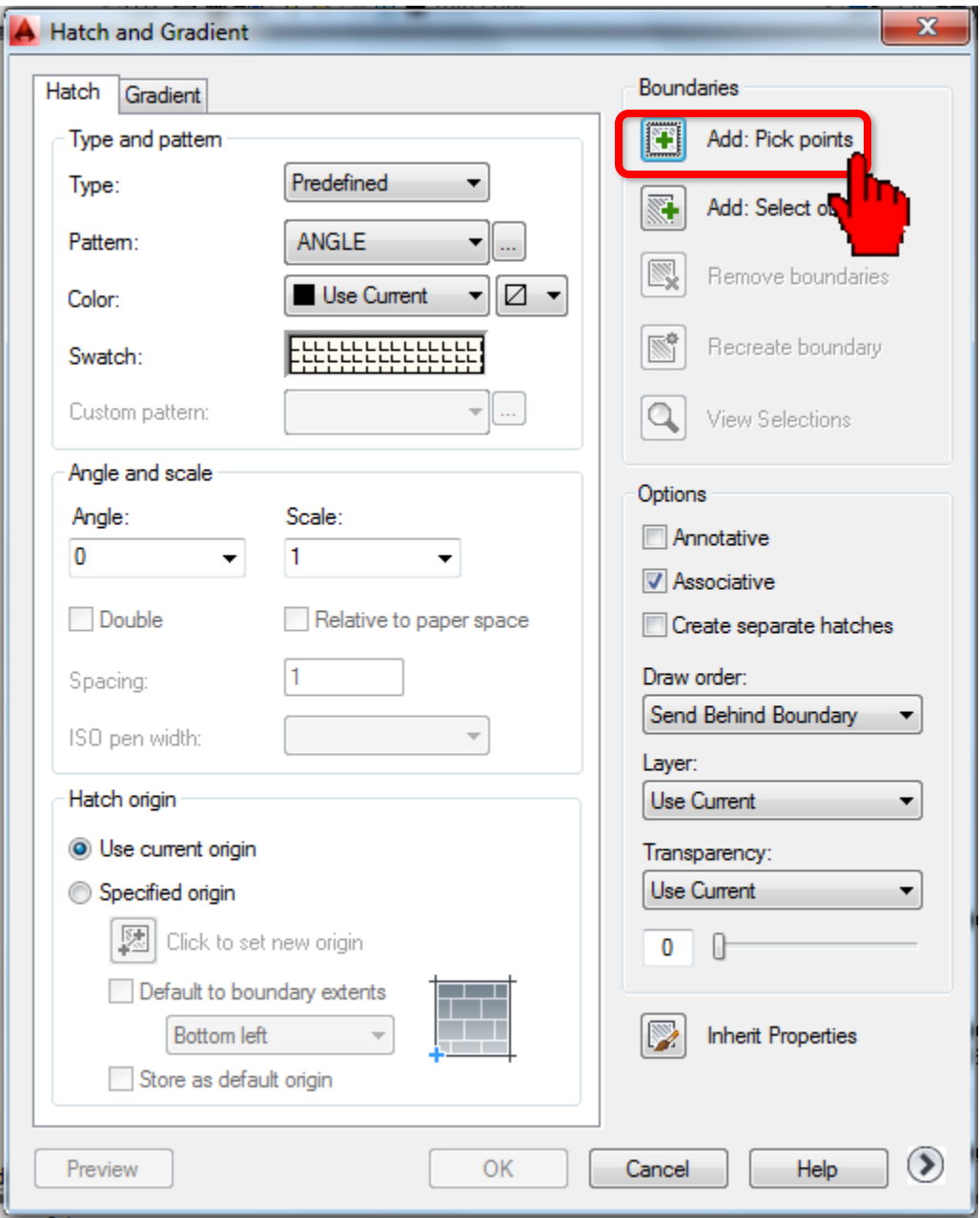

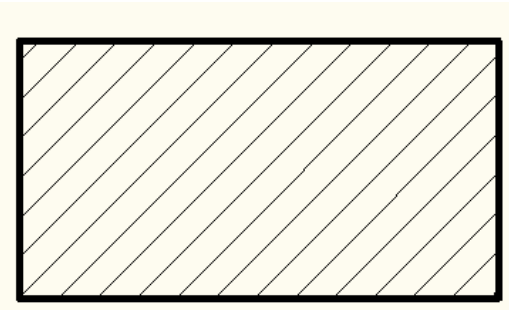
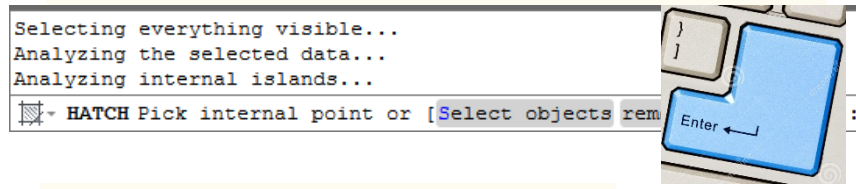
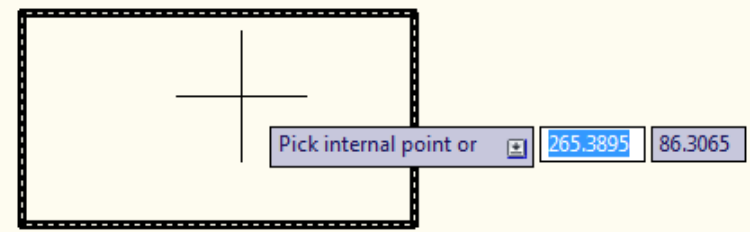
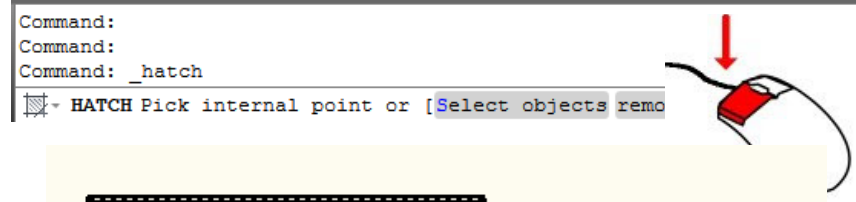
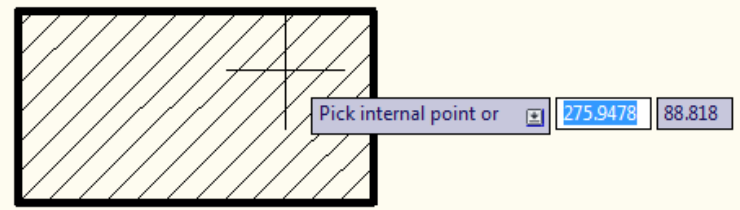
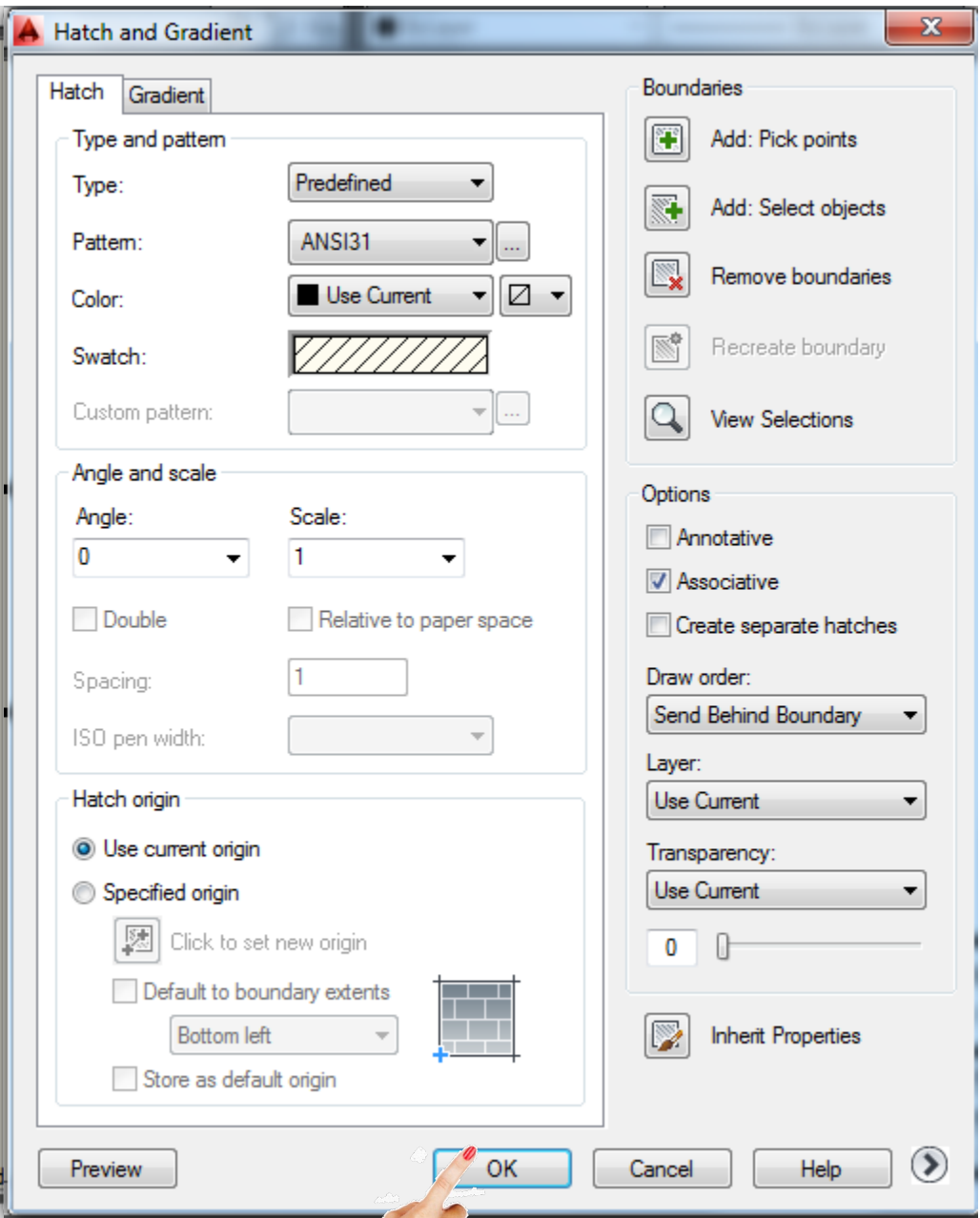

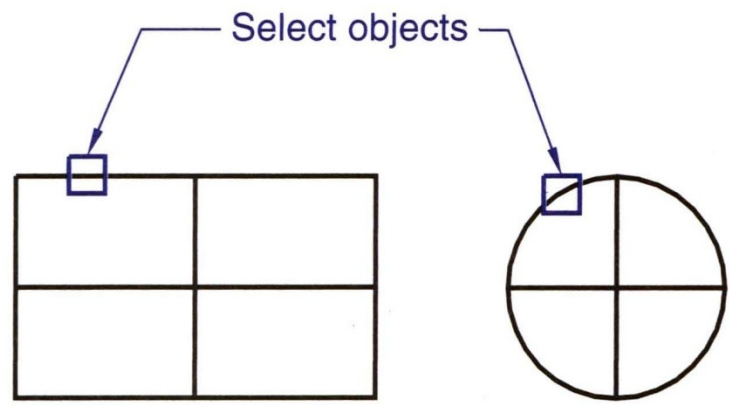
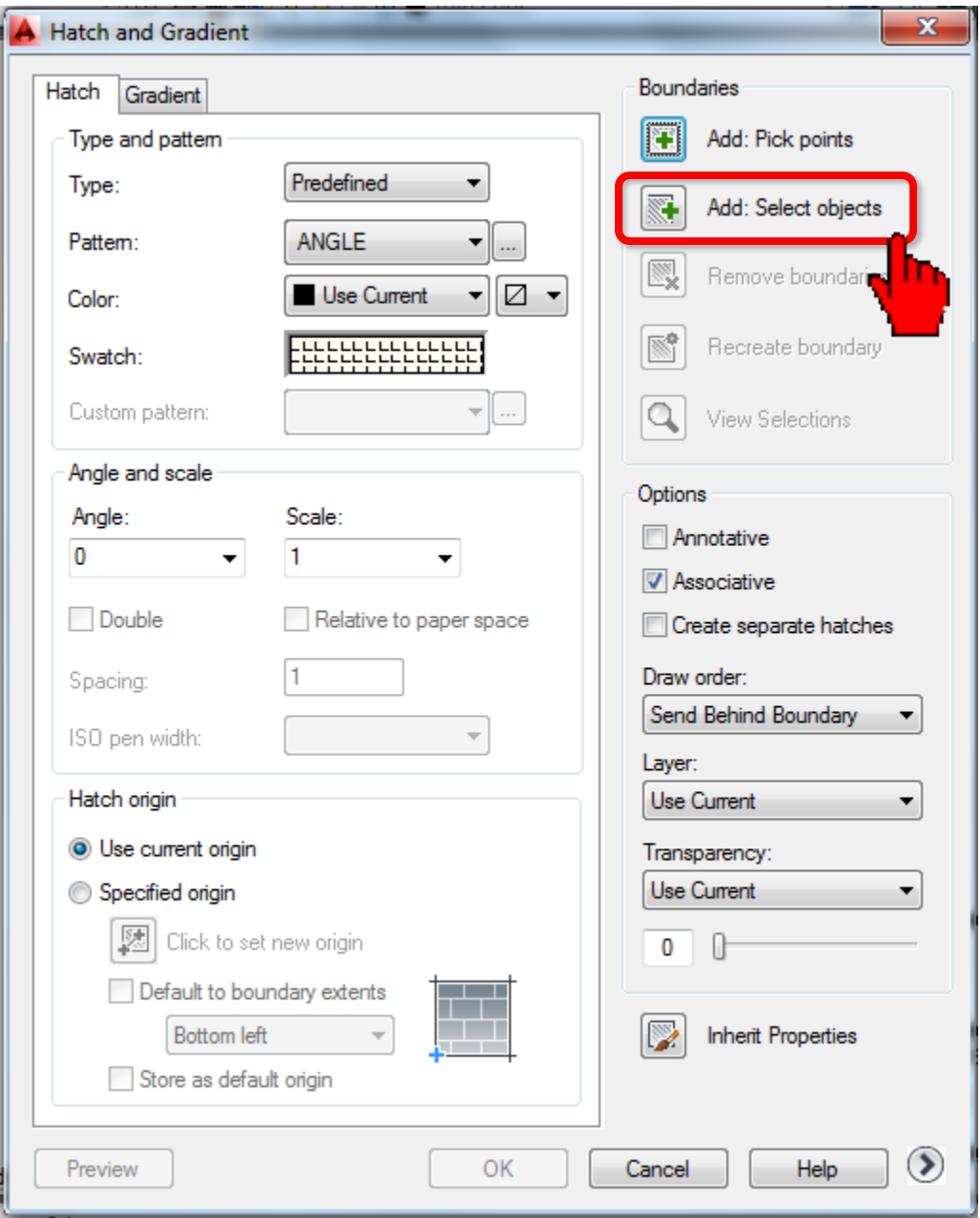

Select objects for hatching

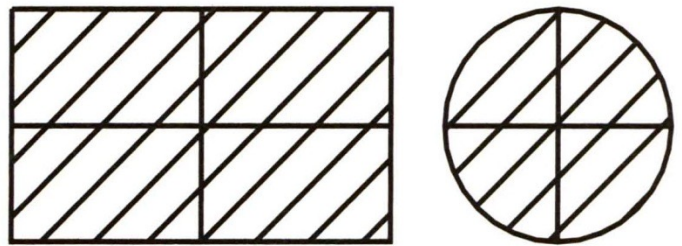

Results

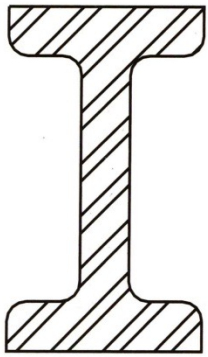
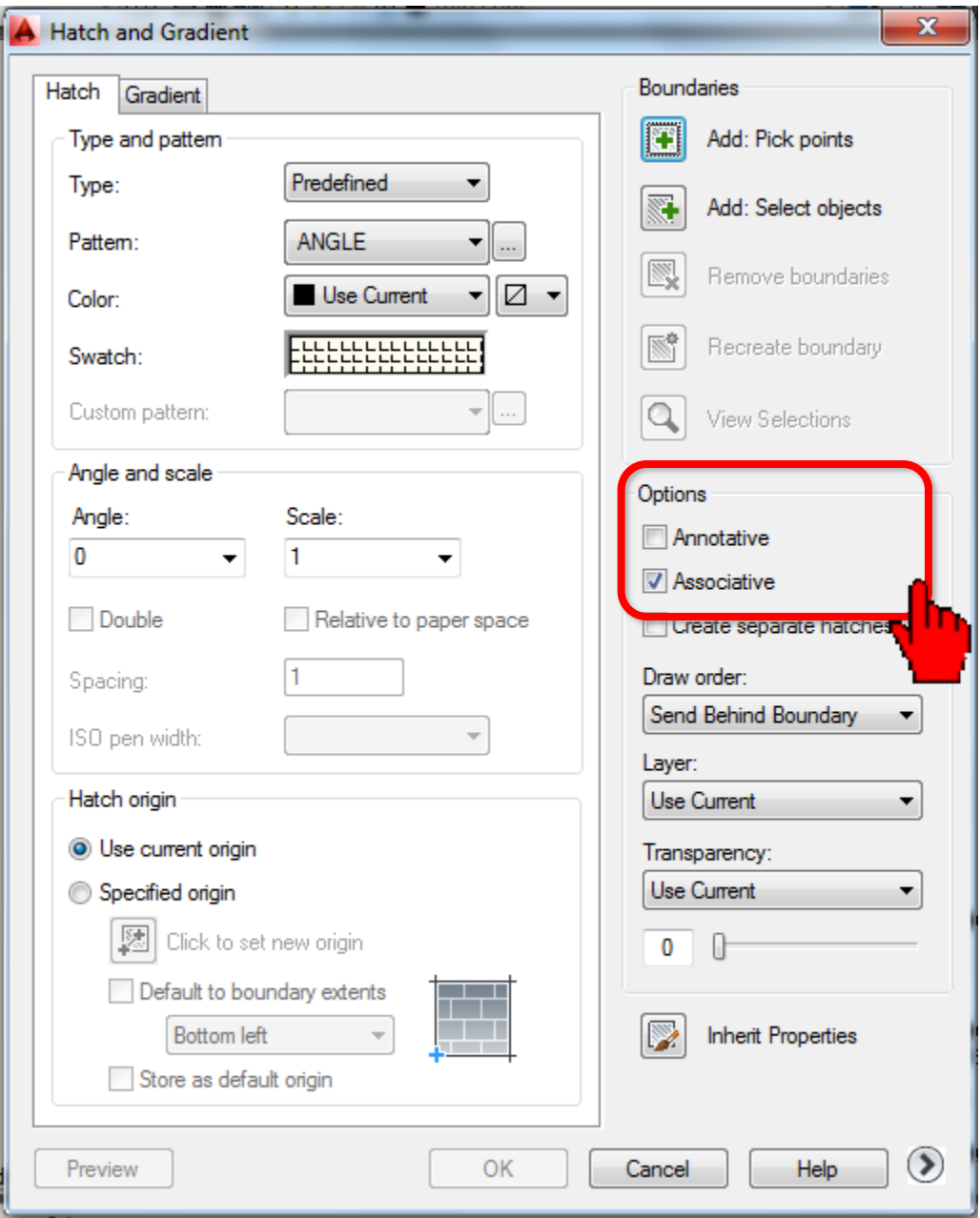

The original hatched object

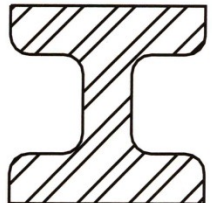

The object edited using the STRETCH command with an associative hatch pattern

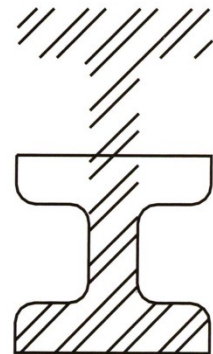

The object edited using the STRETCH command with a nonassociative hatch pattern

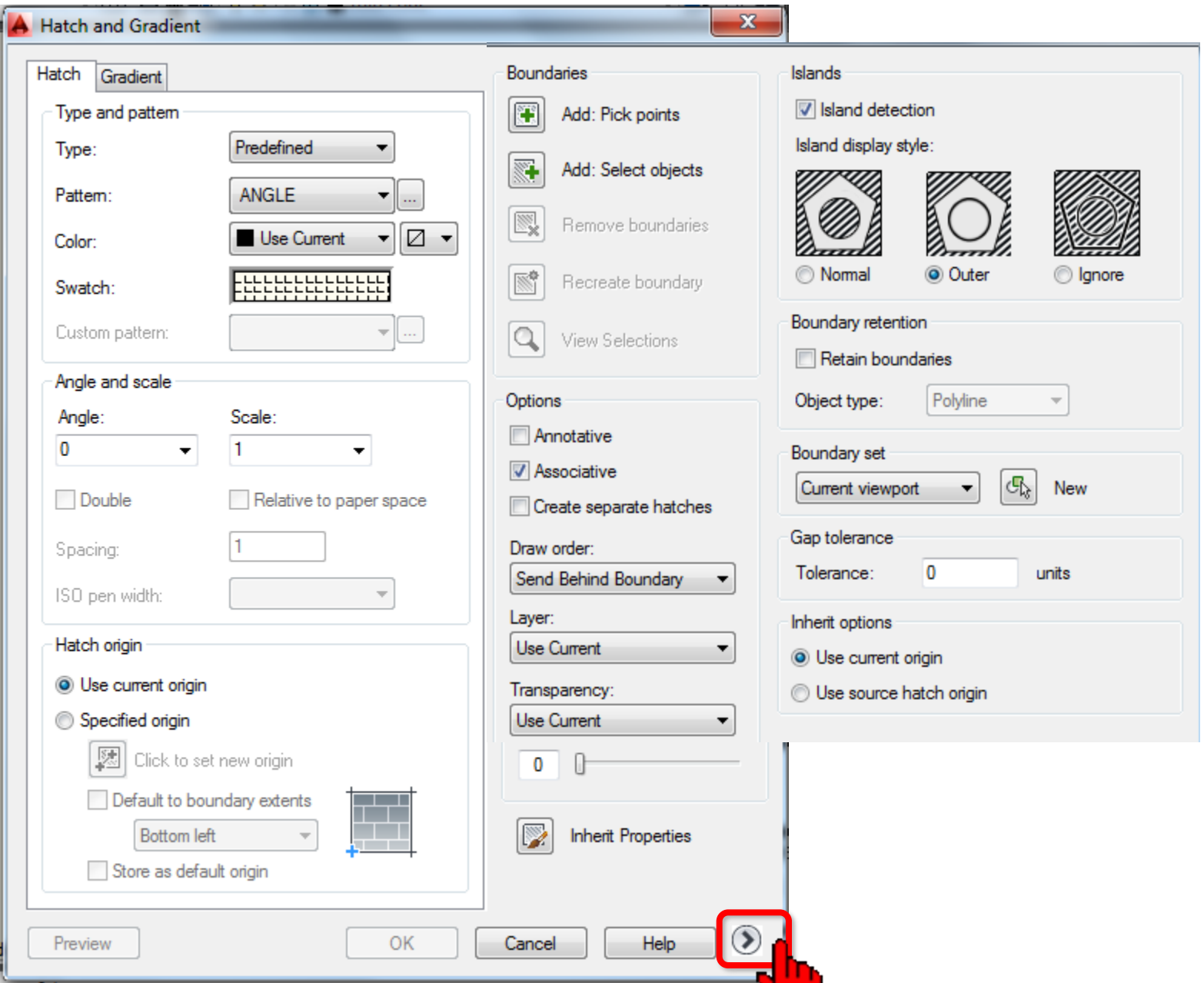

# GRADIENT command

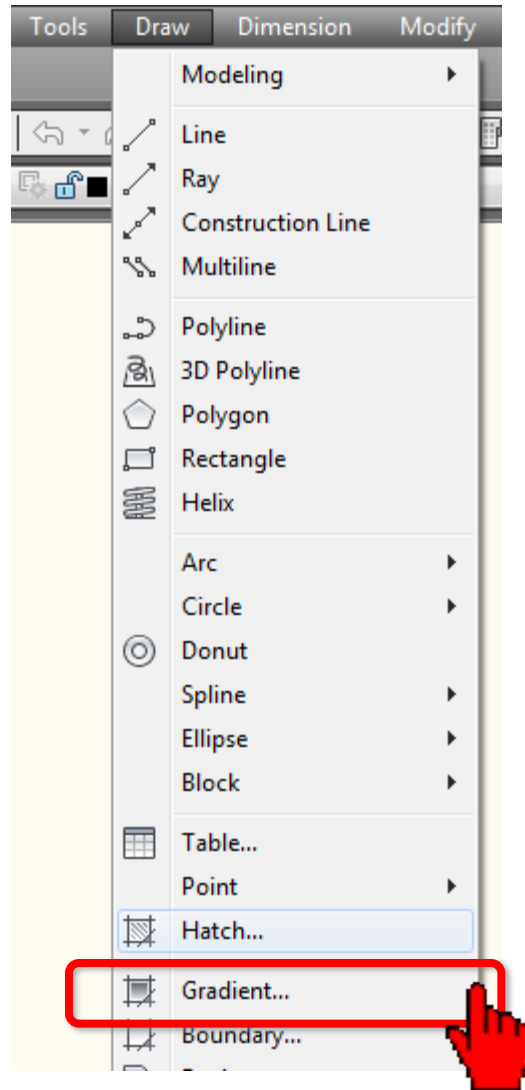
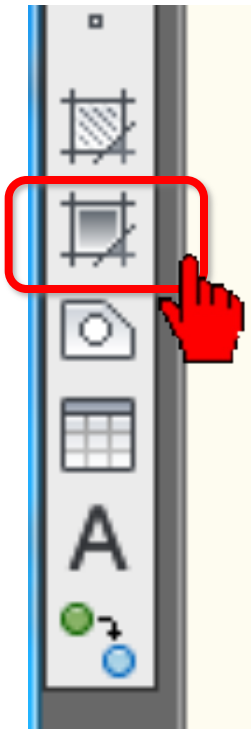

From icon menu

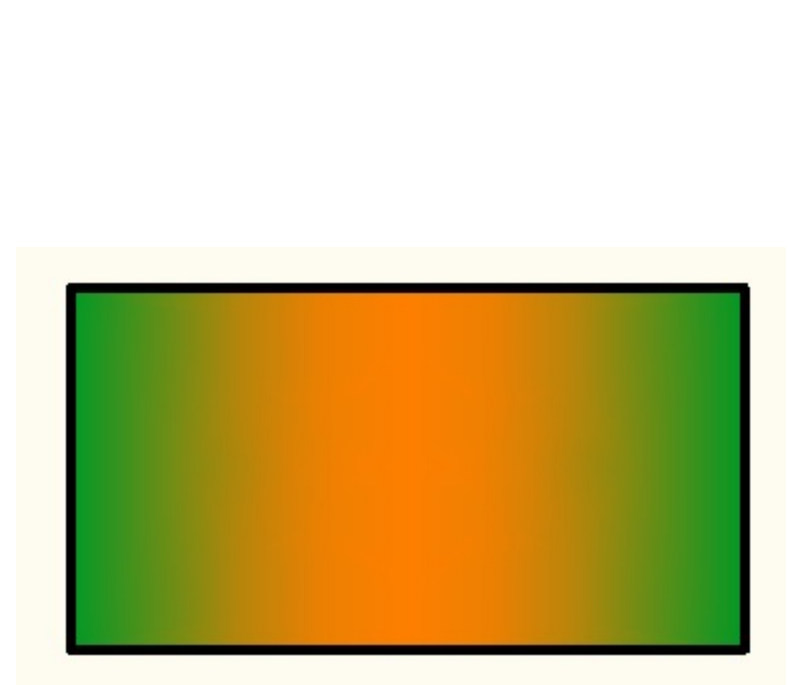
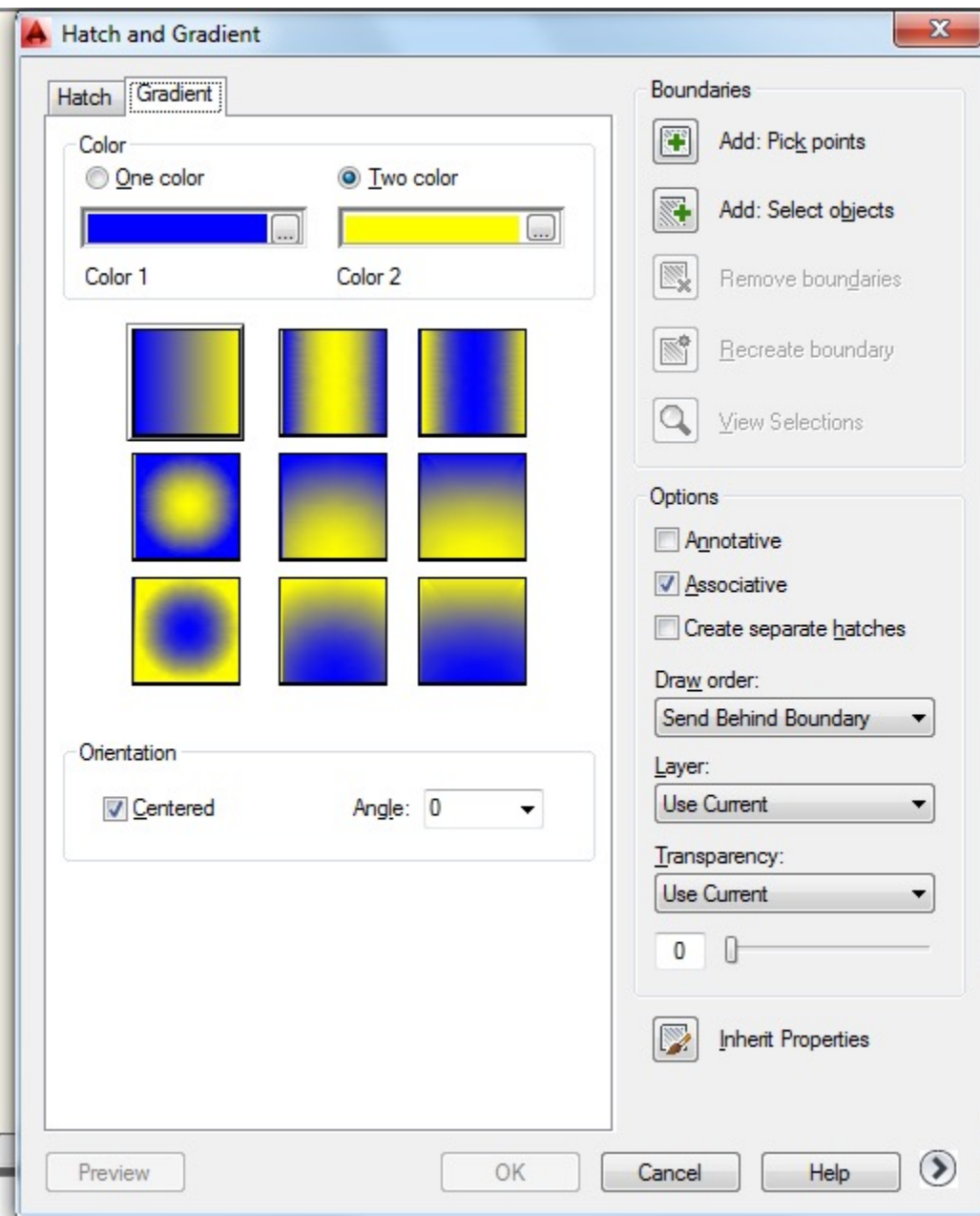

# The following week

---

You will learn 3D (or solid) modeling. The steps to follow are:

- Geometric modeling
- 3D modeling (coordinates)
- Line or wireframe modeling
- Surface modeling
- Solid modeling
- Creating 3D parts
- **Assignment # 5**



# Next week ...

DON'T FORGET

week  
6



**Homework #1**

**Due to : 6th course week**

Using layout A2 (adjusted) draw the following views of **the main body from your design project** in full-size:

- necessary views including at least 2 sectional views and partial views
- at least 3 detail views to show the features in greater detail
- give all necessary dimensions in metric tolerances
- give all necessary surface finishing symbols

Reference [1] **Engineering Graphics**, F.E.Giesecke, et.al., Pearson/Prentice Hall, New Jersey, 2004

<http://www.transport.itu.edu.tr/dersler/lisansdersleri/mak110e/homeworks>

# Assignment #4

---

Page

223

Figure

7.61

You will sketch and complete views

Submit the assignment on time

Upload file into NINOVA

